

- (ES) INSTRUCCIÓN DE MONTAJE DE LA CORTINA ELÉCTRICA SRF-EV Z-Wave
- (FR) INSTRUCTION DU MONTAGE DU STORE OCCULTANT ÉLECTRIQUE SRF-EV Z-Wave
- (GB) ELECTRIC BLACK-OUT BLIND SRF-EV Z-Wave INSTALLATION INSTRUCTION
- (JP) 電動ブラックアウト・ブラインド SRF-EV Z-Wave 施工説明書
- (KR) 전동 롤러 블라인드 SRF-EV Z-Wave 설치 지침

# SRF-EV Z-Wave

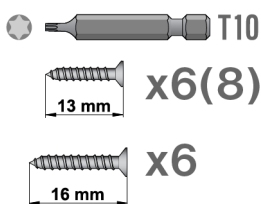

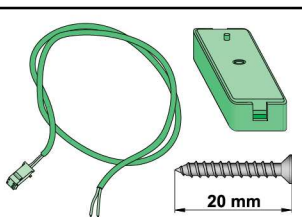
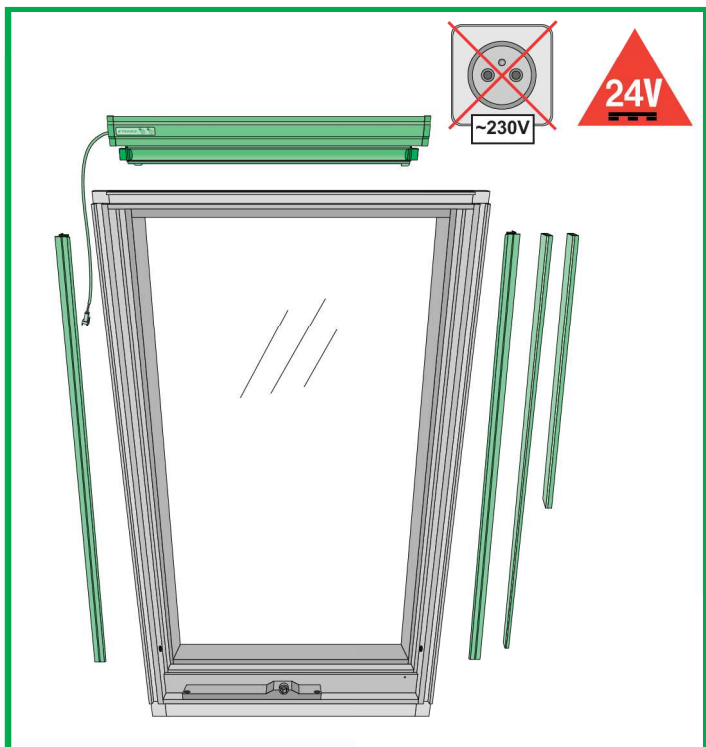
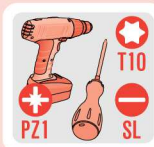

1

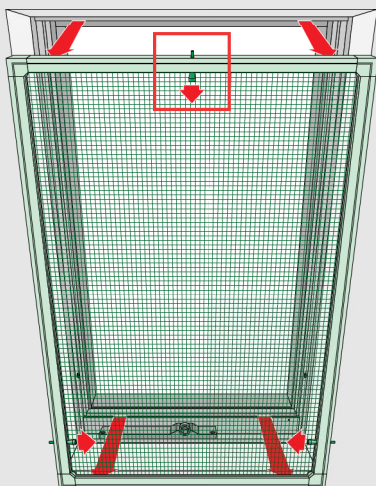

FV

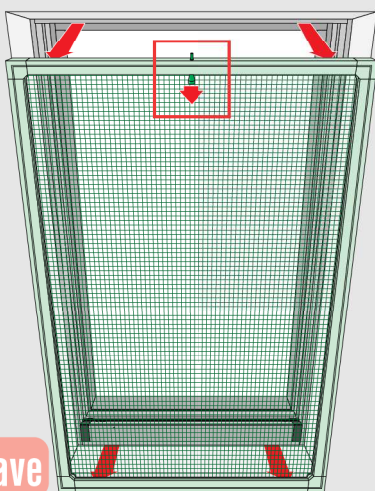
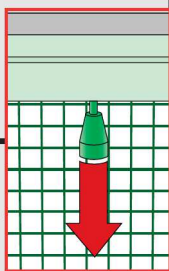

FVE Z-Wave

2

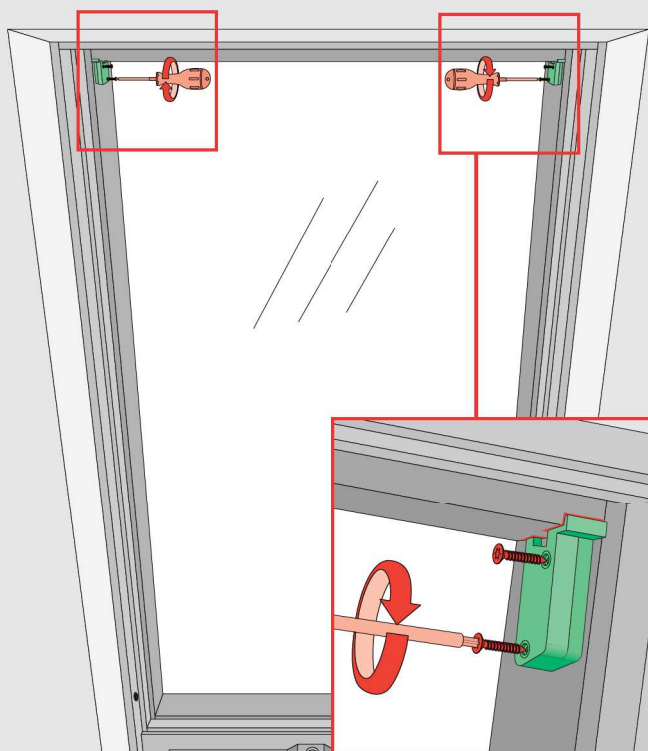
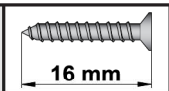

2

3

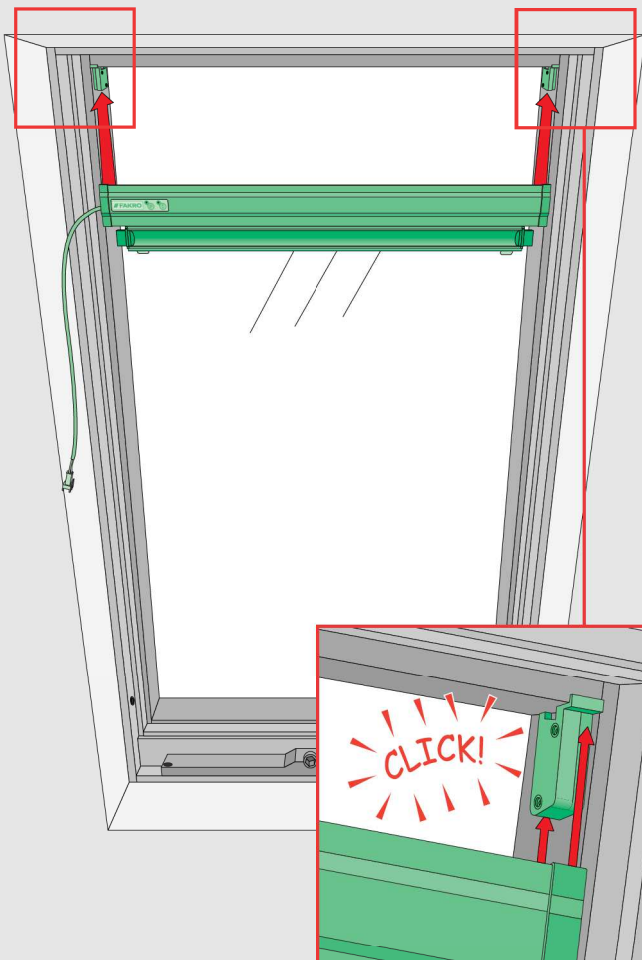

4

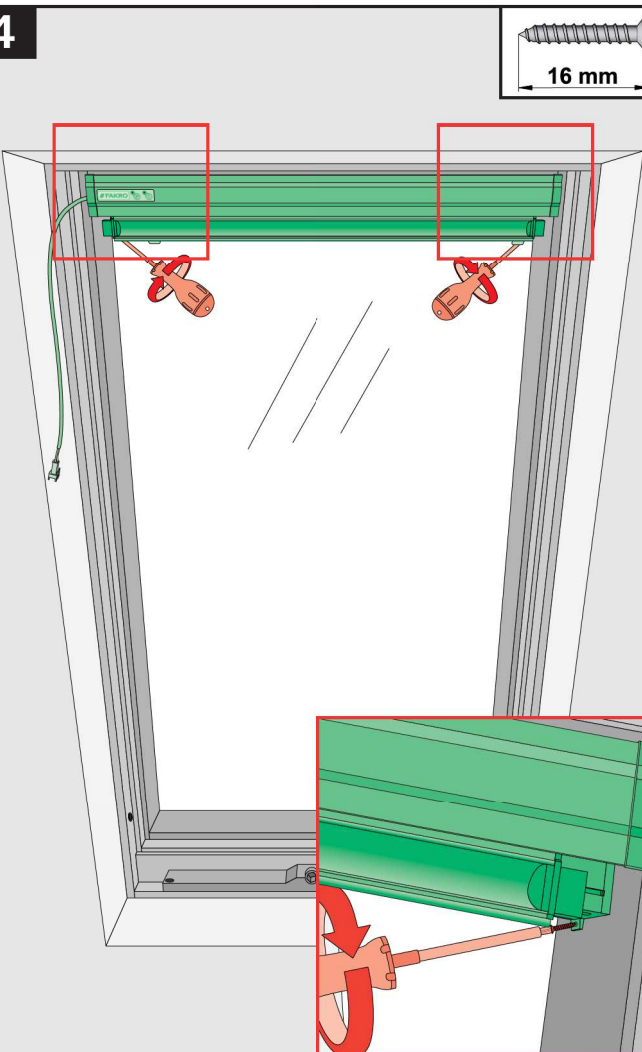

5

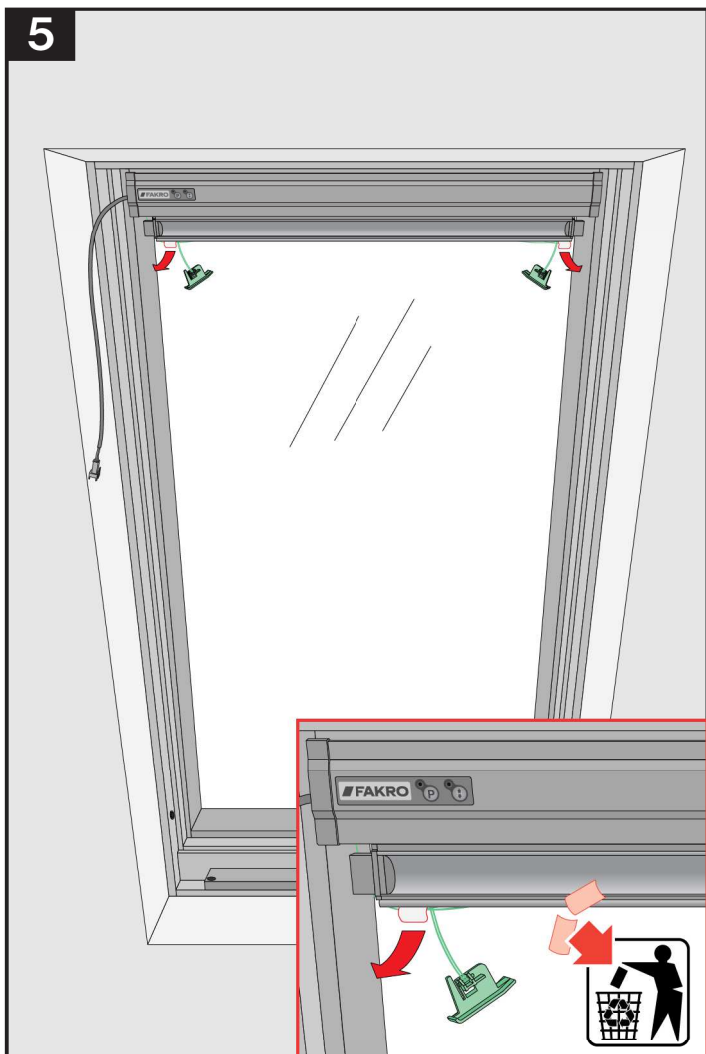

6

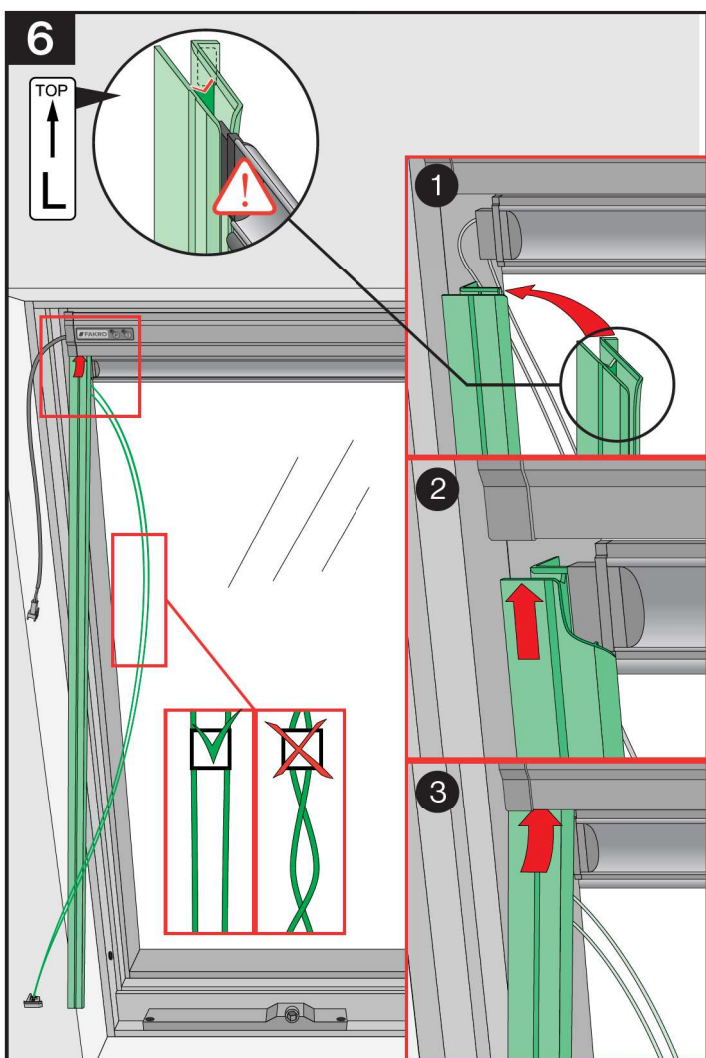

7

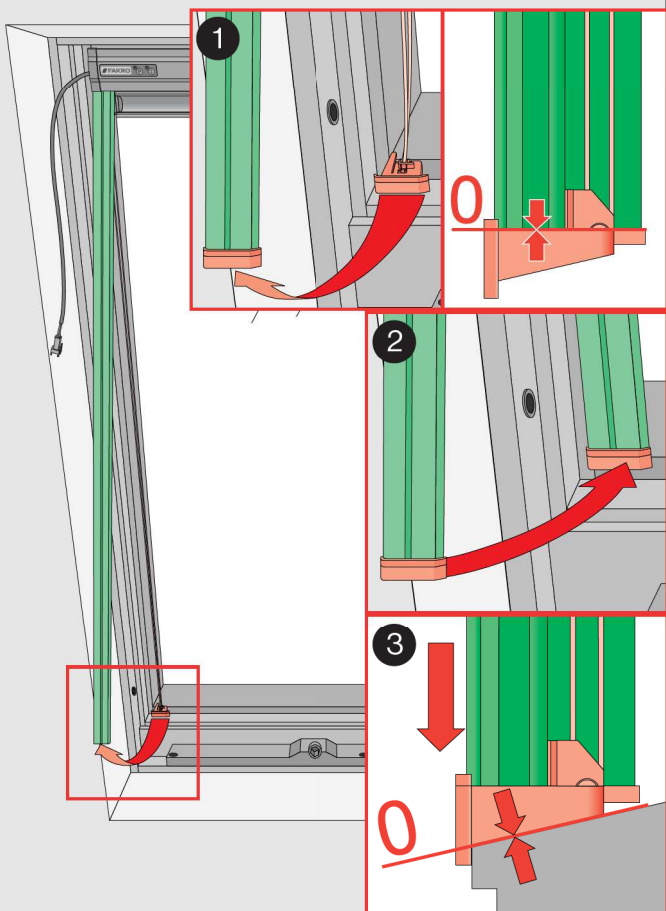

8

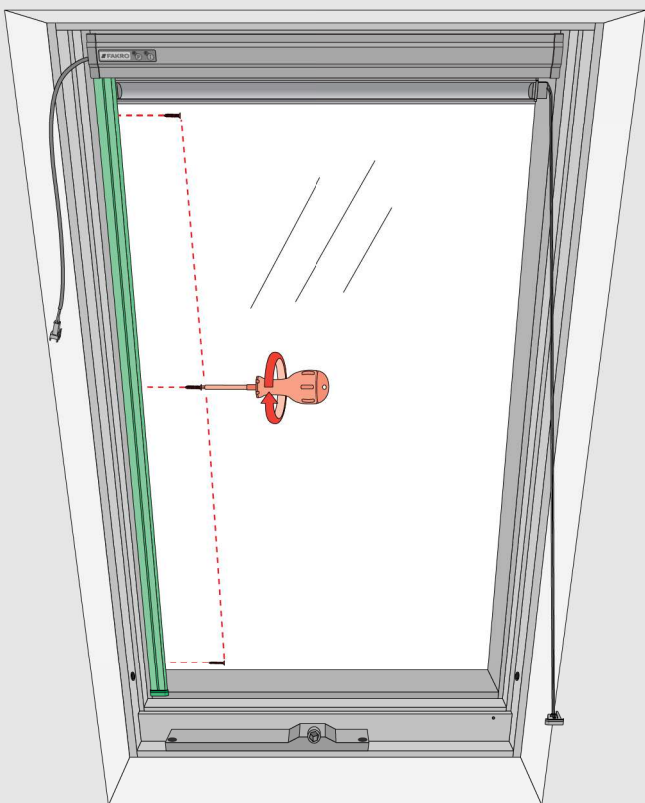

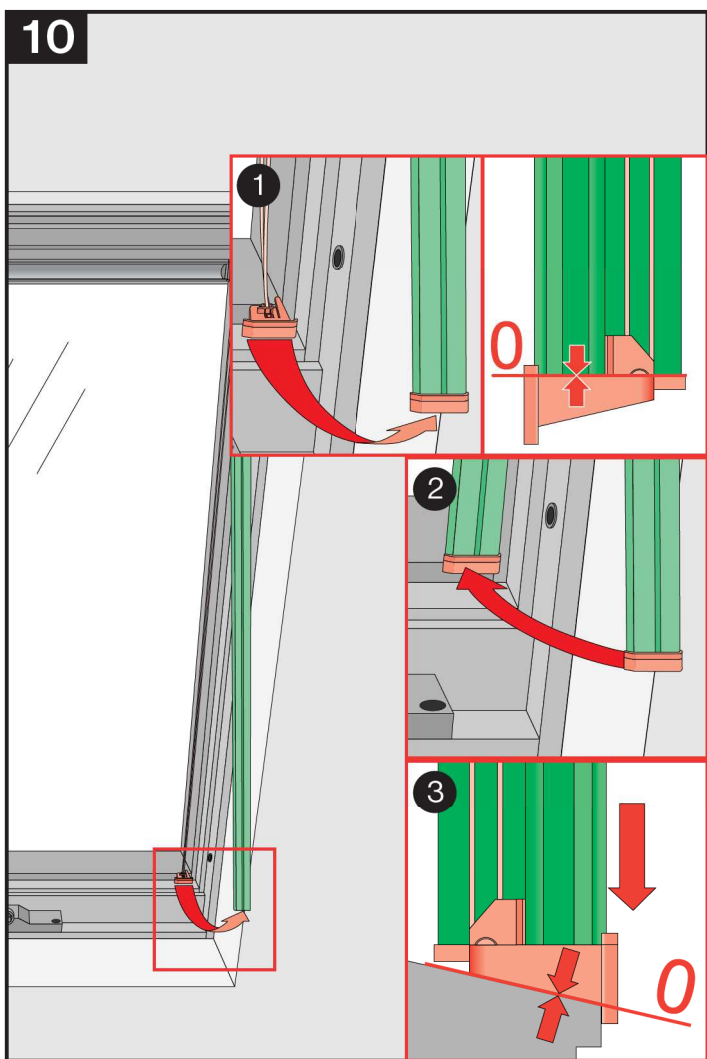
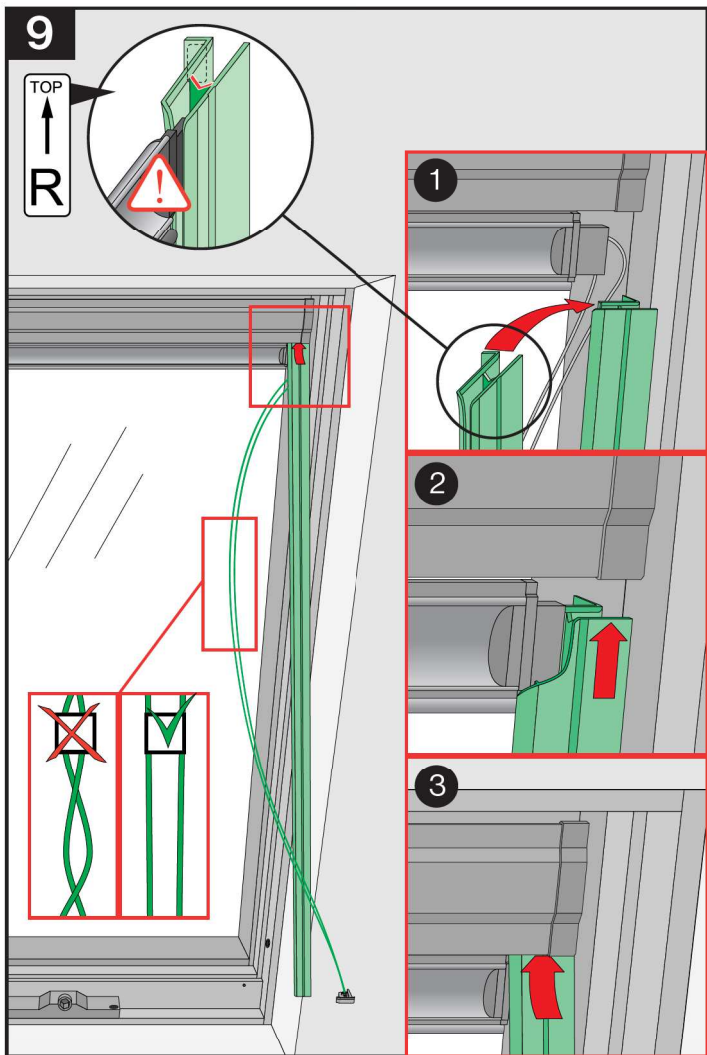

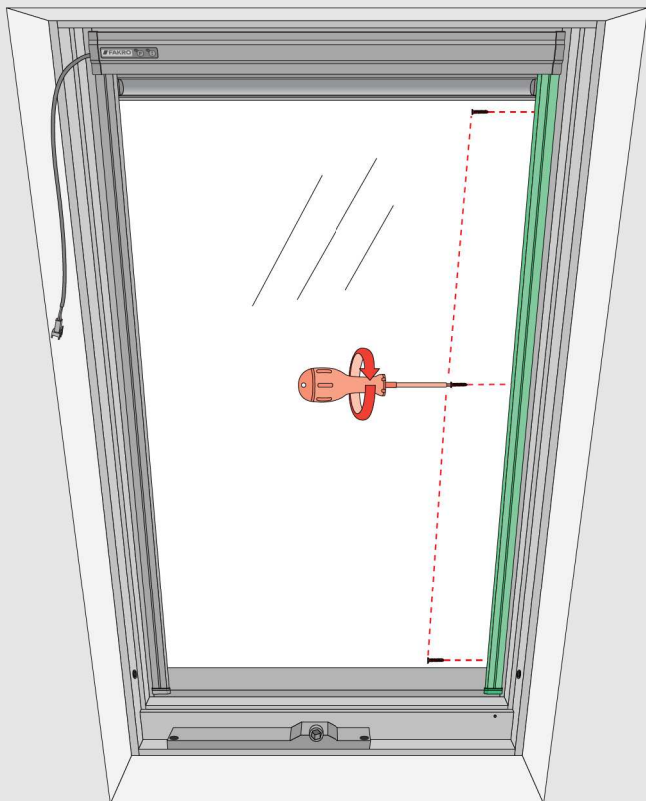

FV ... < 2013.09

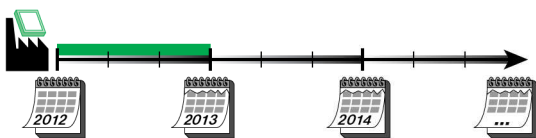

FV 2013.09 ≤ ...

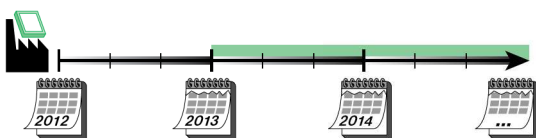

FVE Z-Wave



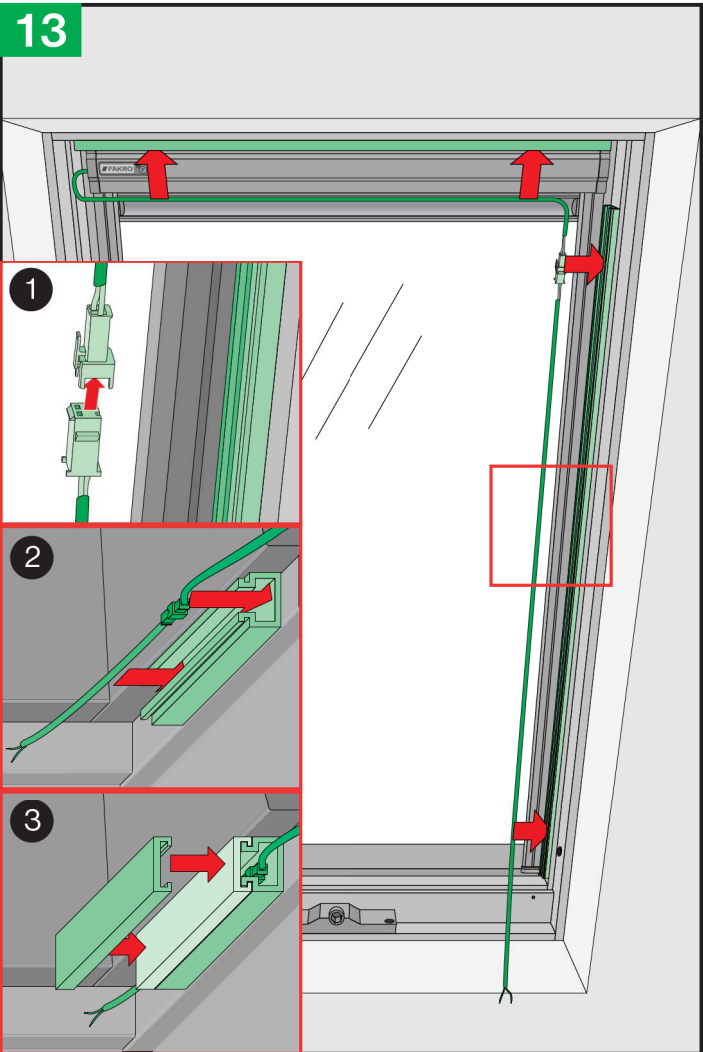
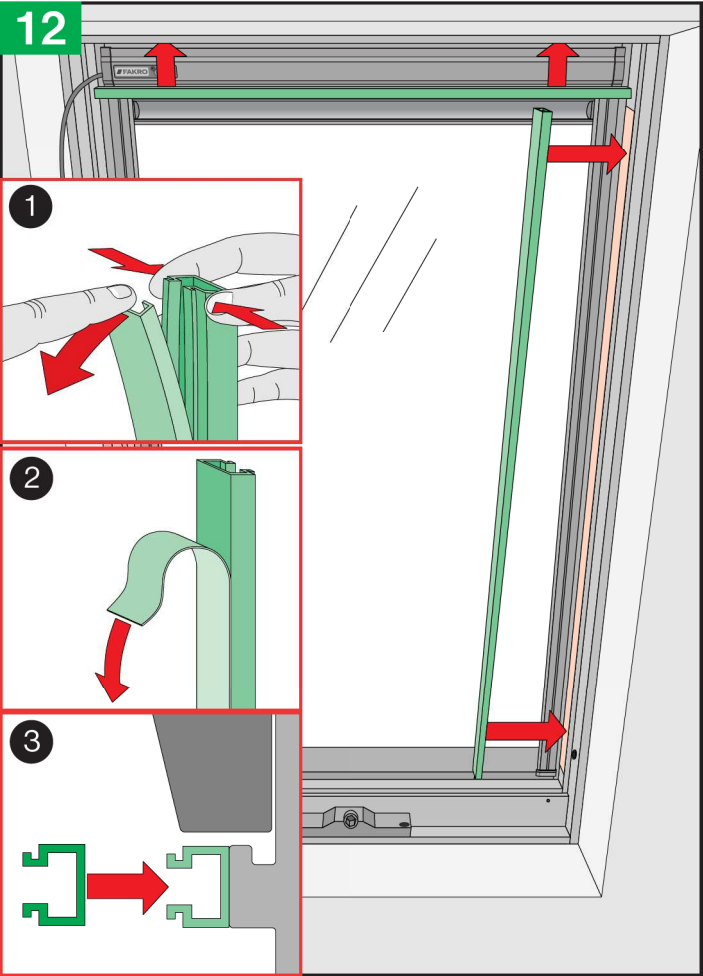



14

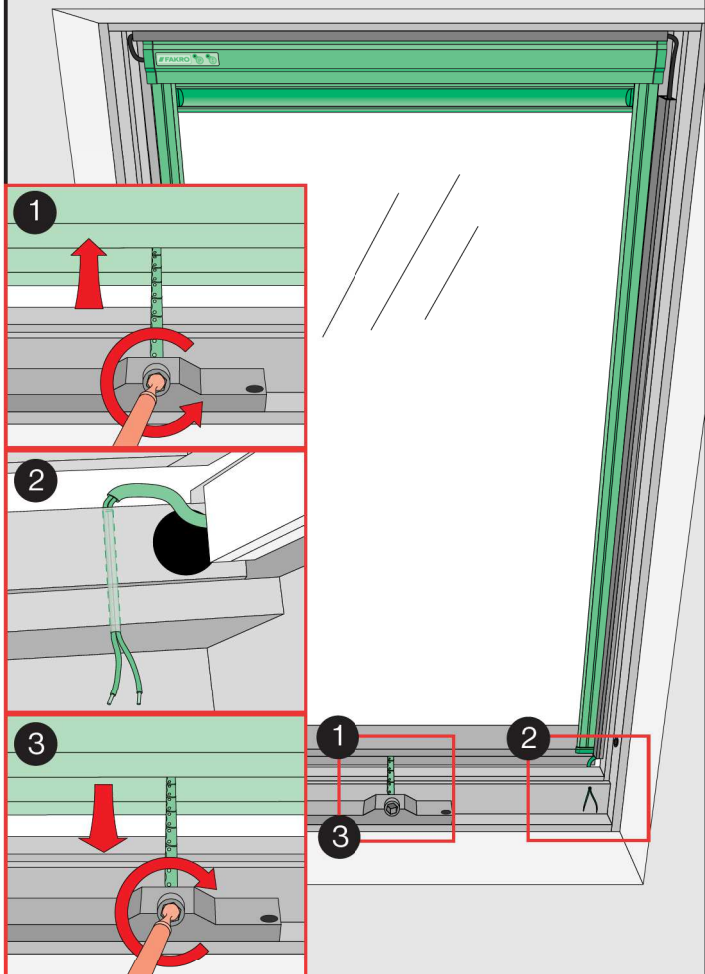

15

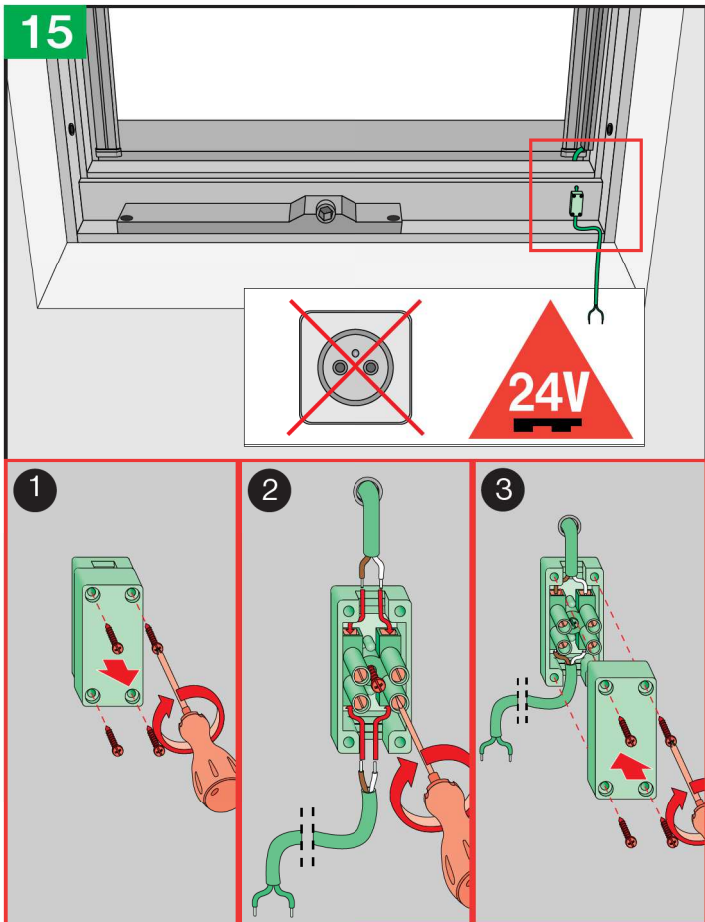

12

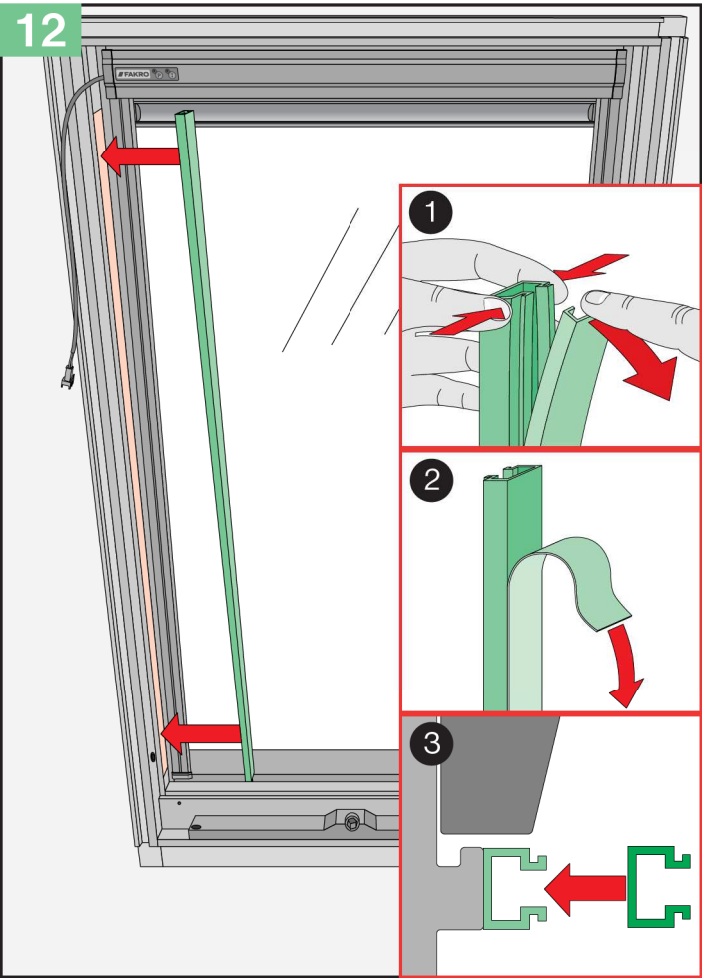

13

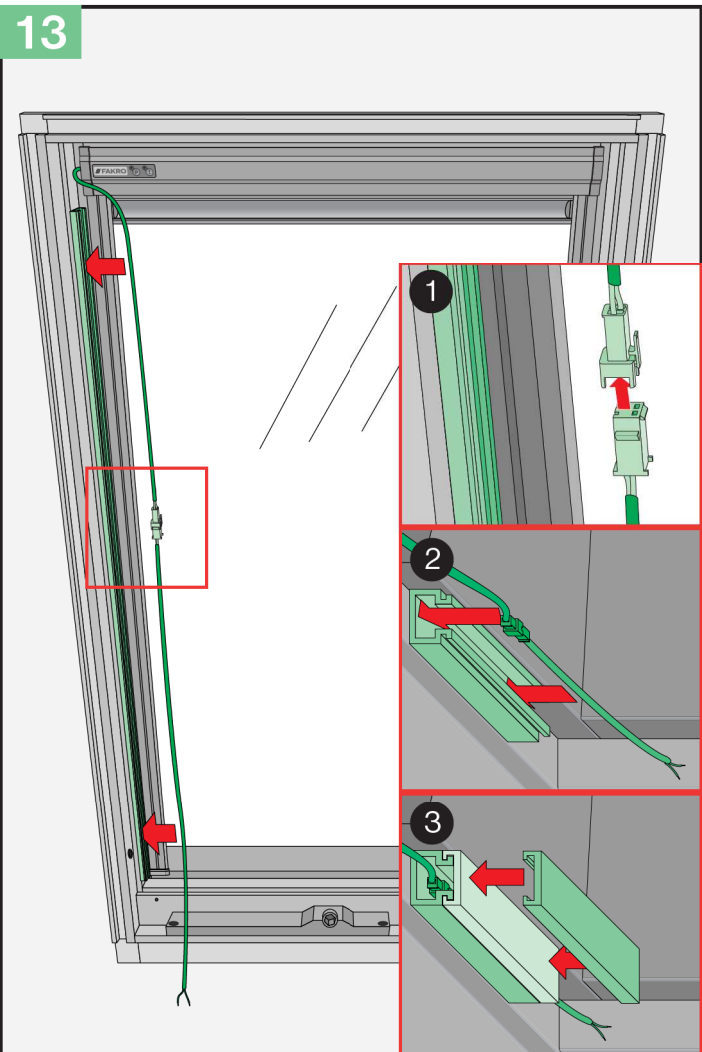

14

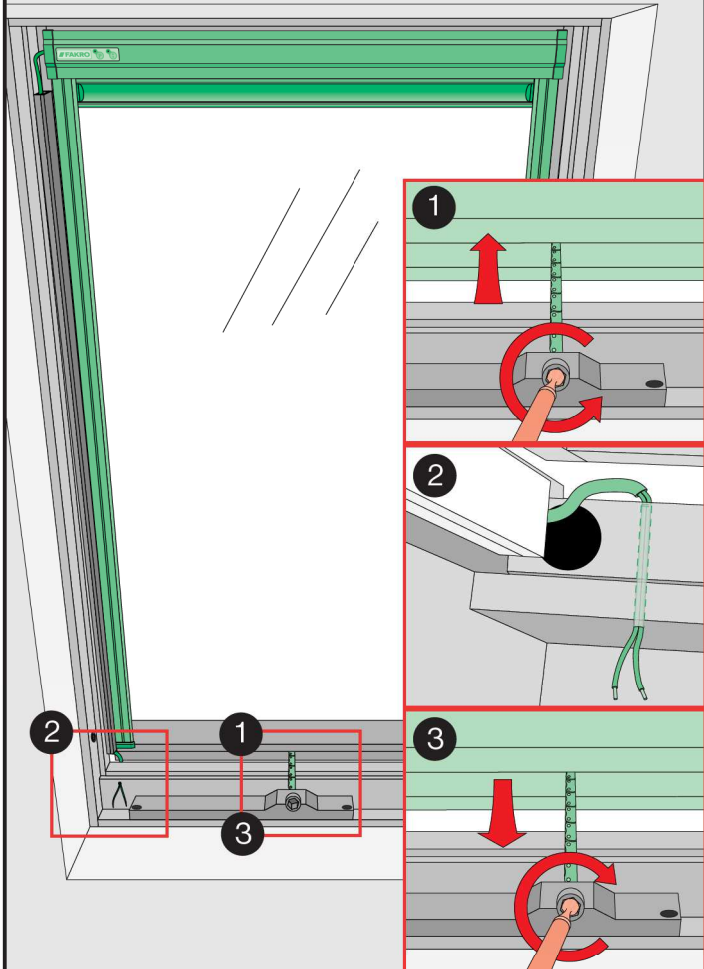

15

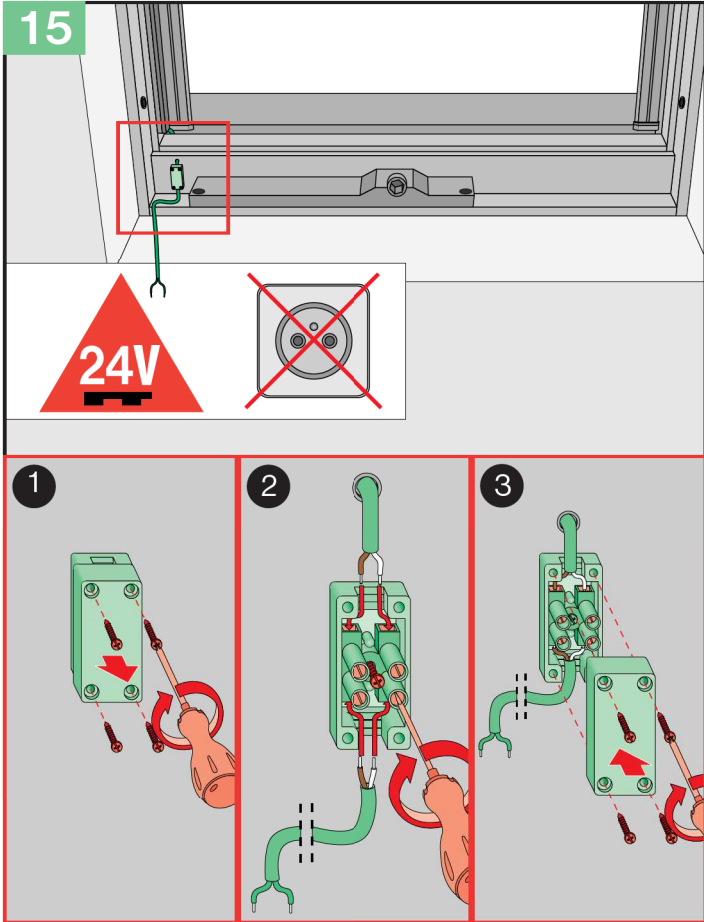

12

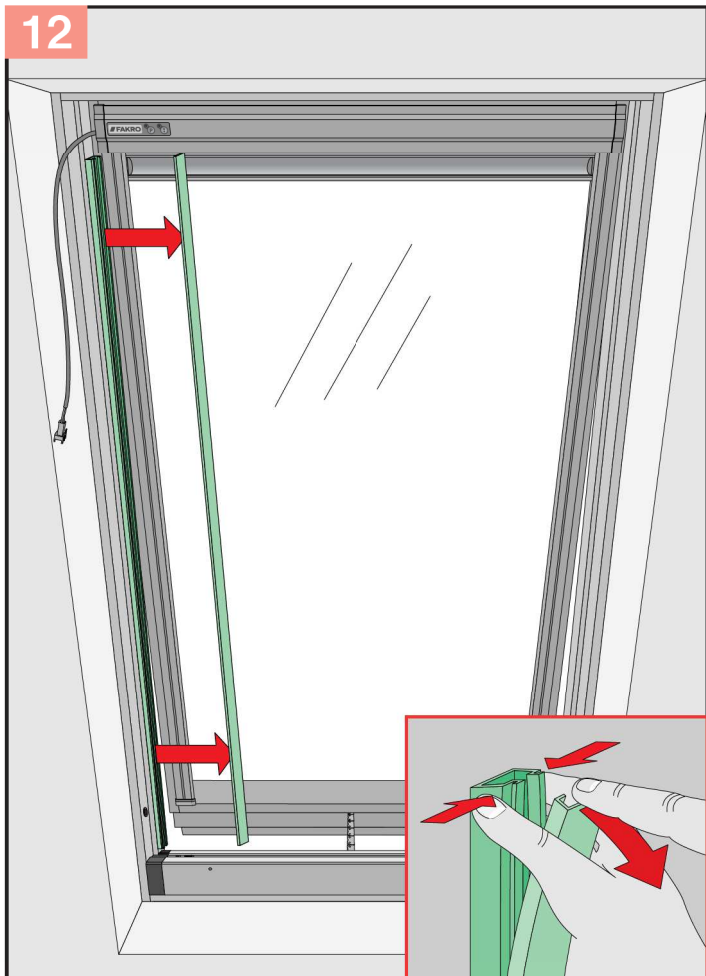

13

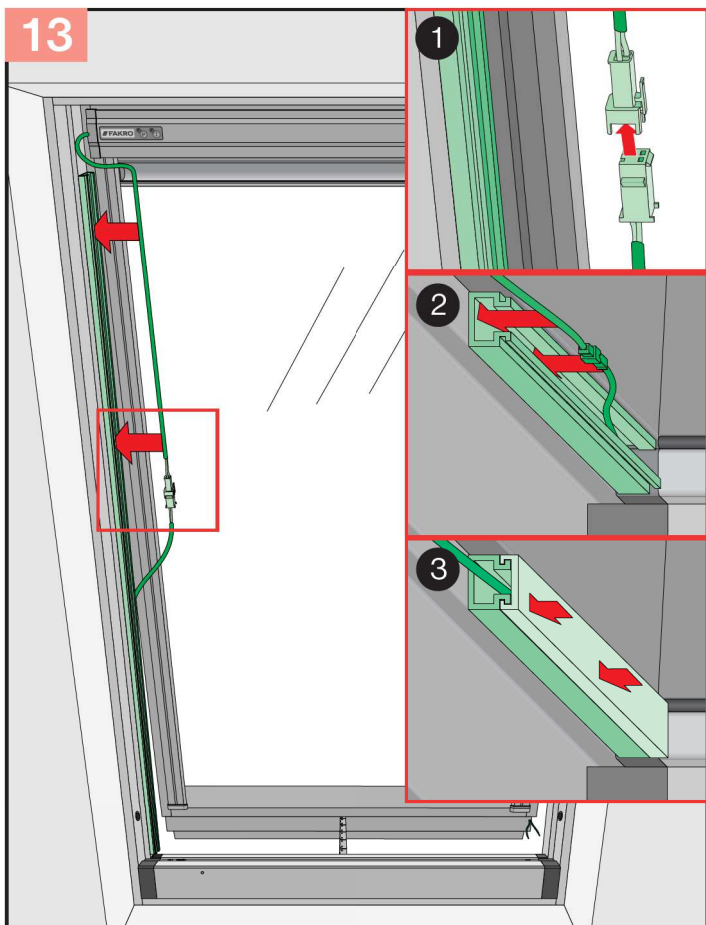

16

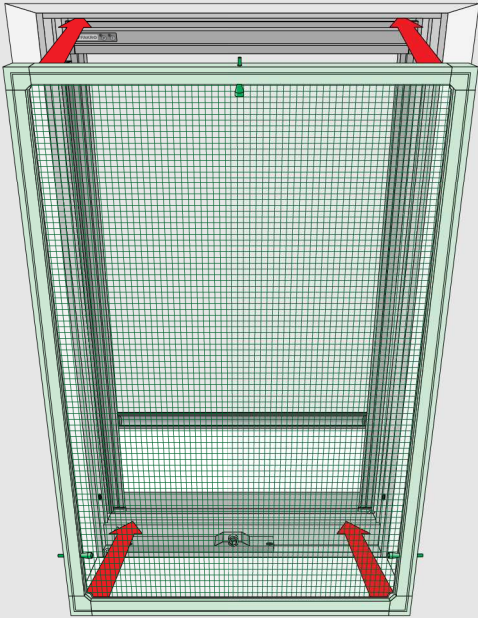

17

FV

FVE Z-Wave

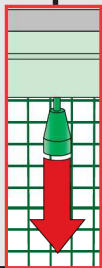
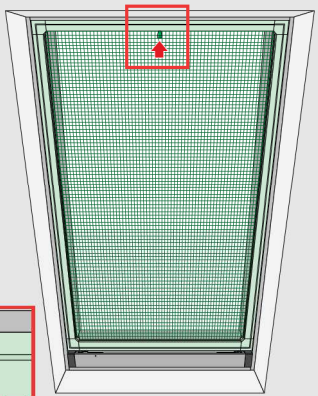
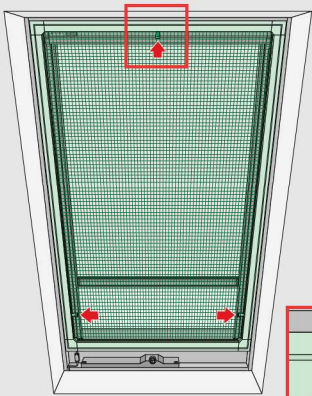

18

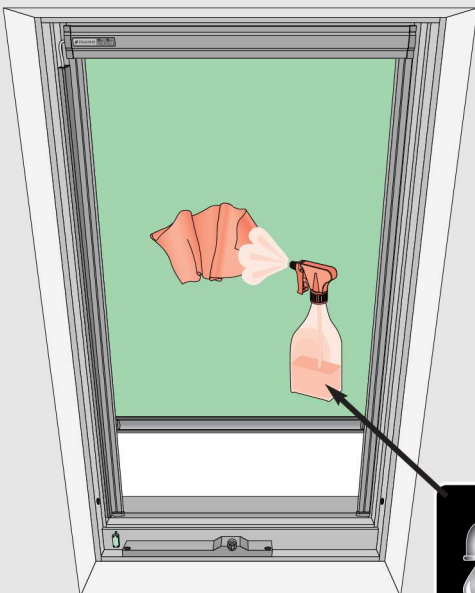

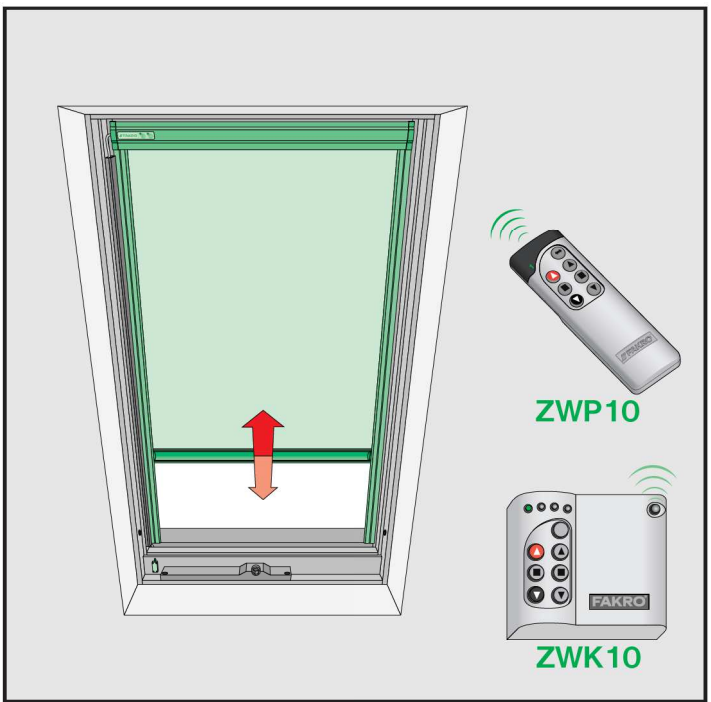

(ES)

Para que funcionen correctamente y seguro los accesorios, hay que usar los elementos de sistemas eléctricos de control de la oferta FAKRO. En el caso de usar otros sistemas eléctricos Fakro y los vendedores no asumen la responsabilidad por su funcionamiento incorrecto, deterioro del producto u otros elementos y lesiones físicas.

(FR)

Afin d'assurer le bon fonctionnement des accessoires, il est conseillé d'utiliser les systèmes de commande FAKRO. Fakro et ses vendeurs ne sont pas responsables du mauvais fonctionnement ou tout endommagement causé par les systèmes de commande autres que Fakro.

(GB)

In order to assure proper functioning of the blinds, it is recommended to use only the controls available from Fakro offer. In case of use of controls other than these offered by Fakro, Fakro and suppliers will not be responsible for improper functioning, possible damages, or injuries.

(JP)

ブラインドを操作する際は、弊社の純正リモコンを使用し、操作を行ってください。それ以外のリモコンでブラインドを操作し、故障・破損等が発生した場合、弊社及び販売会社は製品保証に関して一切責任は負いかねますので、ご了承お願い致します。

(KR)

블라인드의 적절한 작동을 보장하기 위해서, 오직 FAKRO사에서 제공한 컨트롤러만 사용하기를 권장합니다. FAKRO에서 제공되지 않은 다른 컨트롤러를 사용할 경우, FAKRO 그리고 공급자는 적절하지 않은 작동, 일어날 수 있는 손상 또는 부상의 책임을 지지 않습니다.



**ES** El fabricante y el vendedor no tienen ninguna responsabilidad por el incumplimiento de la ley vigente, normas de construcción y exigencias de seguridad por parte del usuario del producto, arquitecto, instalador o el propietario del edificio.

**FR** Le fabricant et le revendeur ne prend aucune responsabilité de ne pas respecter les lois applicables, les règlements sur les bâtiments et les exigences de sécurité par l'utilisateur du produit, l'architecte, l'installateur ou le propriétaire du bâtiment.

**GB** Manufacturer and Seller shall bear no liability for failure to comply with the applicable laws, building codes and safety requirements by the user of the product, architect, fitter or owner of the building.

**JP** 製品の使用者・建築士・施工業者・オーナーの皆様へ: 建築規制、安全に関する条件等のルール及び法律に従わず、不都合が発生した場合、メーカー及び販売会社は一切責任は負いかねますので、ご了承ください。

**KR** 제조사와 판매자는 제품의 사용자, 건축가, 설비 기술자 또는 건물의 소유자가 관련 법률, 건축법 및 안전 요구 사항의 준수하기 위한 실패에 대해서는 책임을 지지 않습니다.